

A2

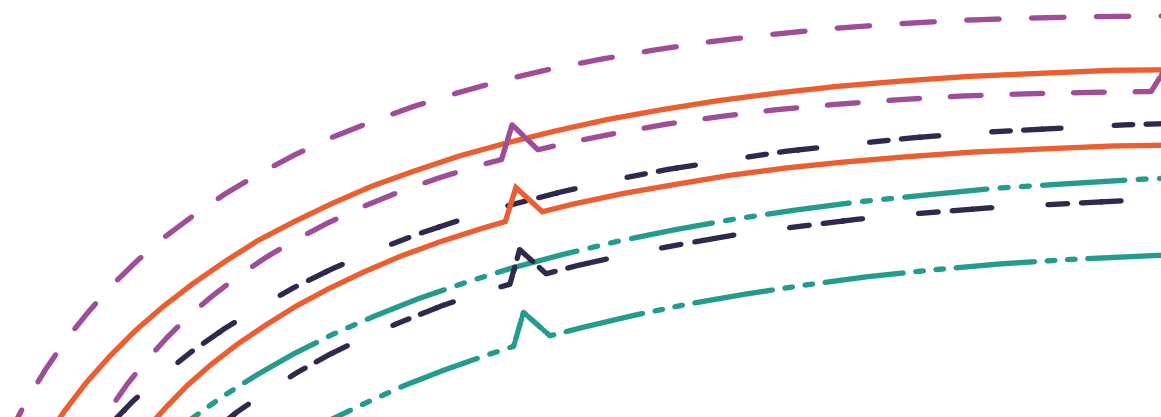

Couper 1X au pli Tissue
Couper 1X au pli Doubleure

GILET
Dos



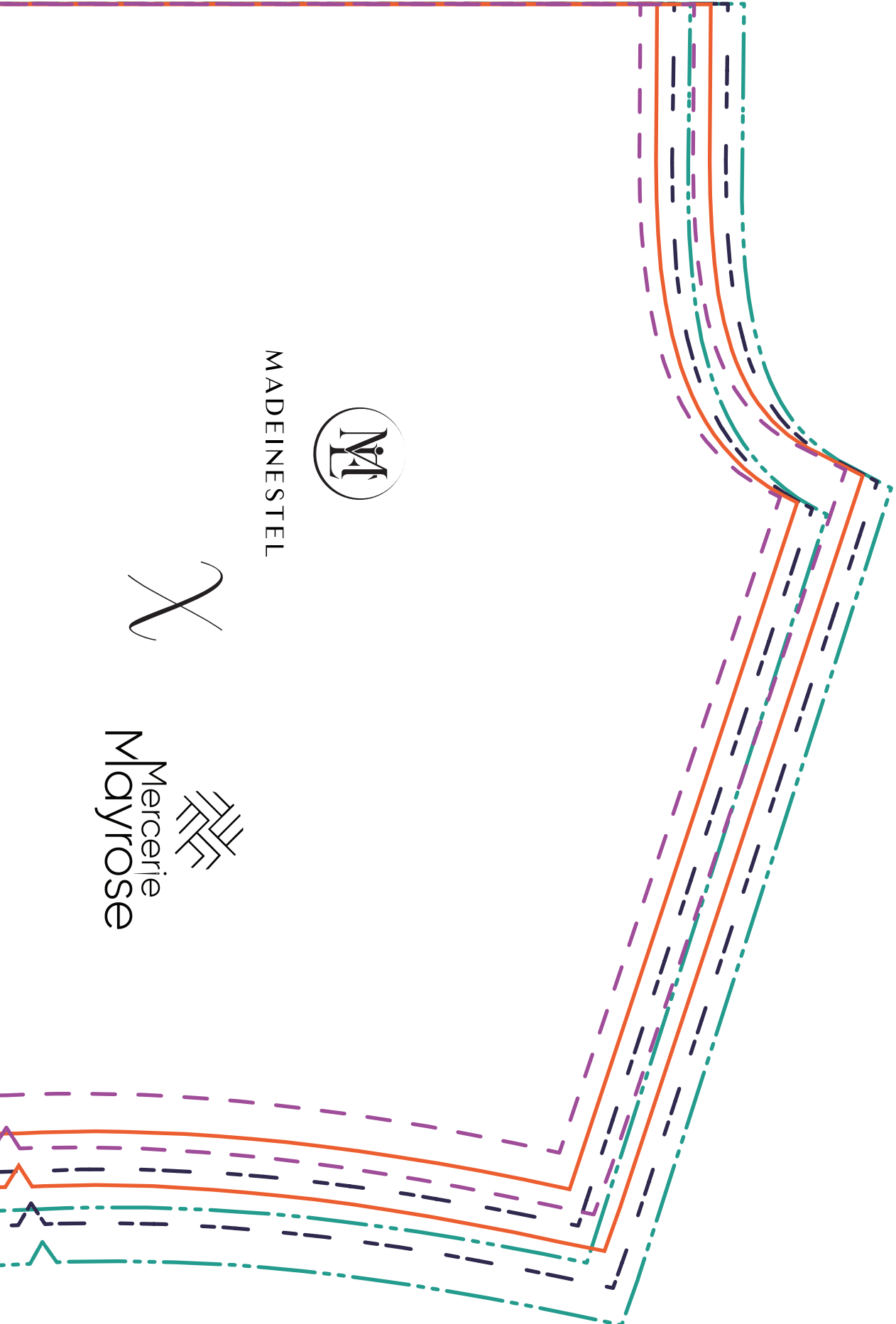

MADINESTEL



Mercerie
Mayrose

B1

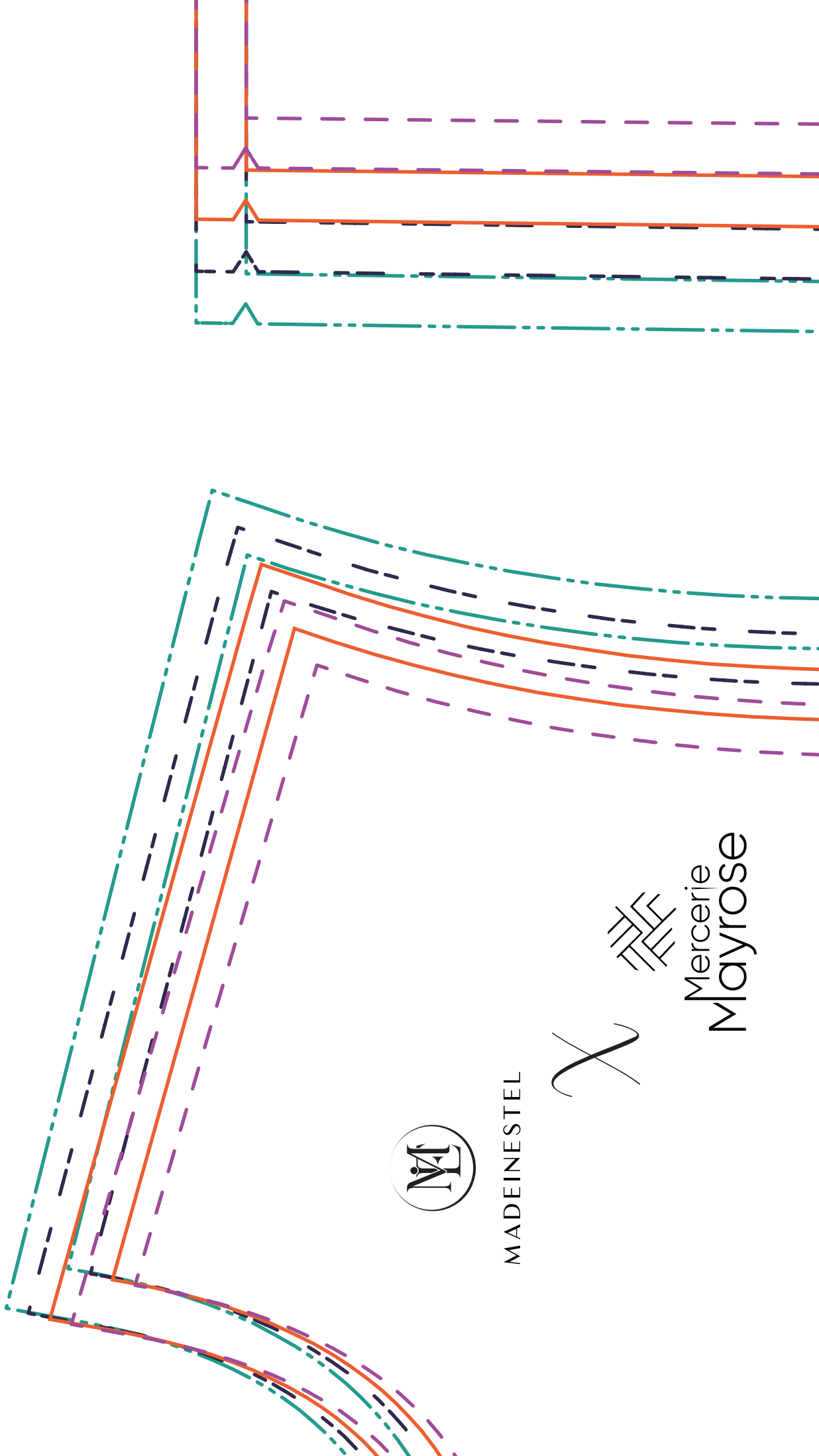

MADEINESTEL



Mercerie
Mayrose

B2

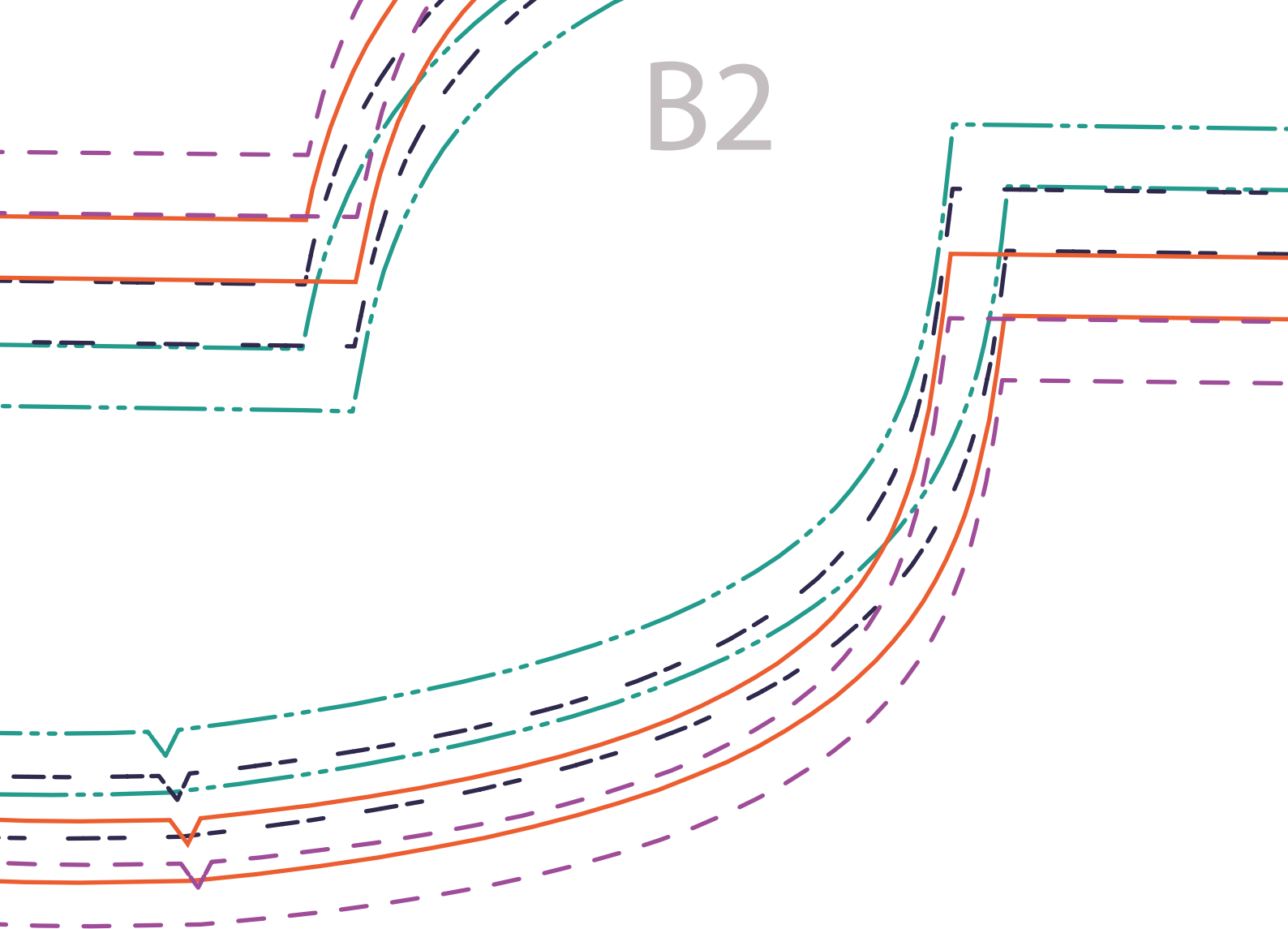

GILET
Devant

Couper

2X en Miroir Tissu

2X en Miroir Doublure

Marges de couture comprises 1cm

Tous droits réservés
Reproduction interdite, usage privé uniquement

C1

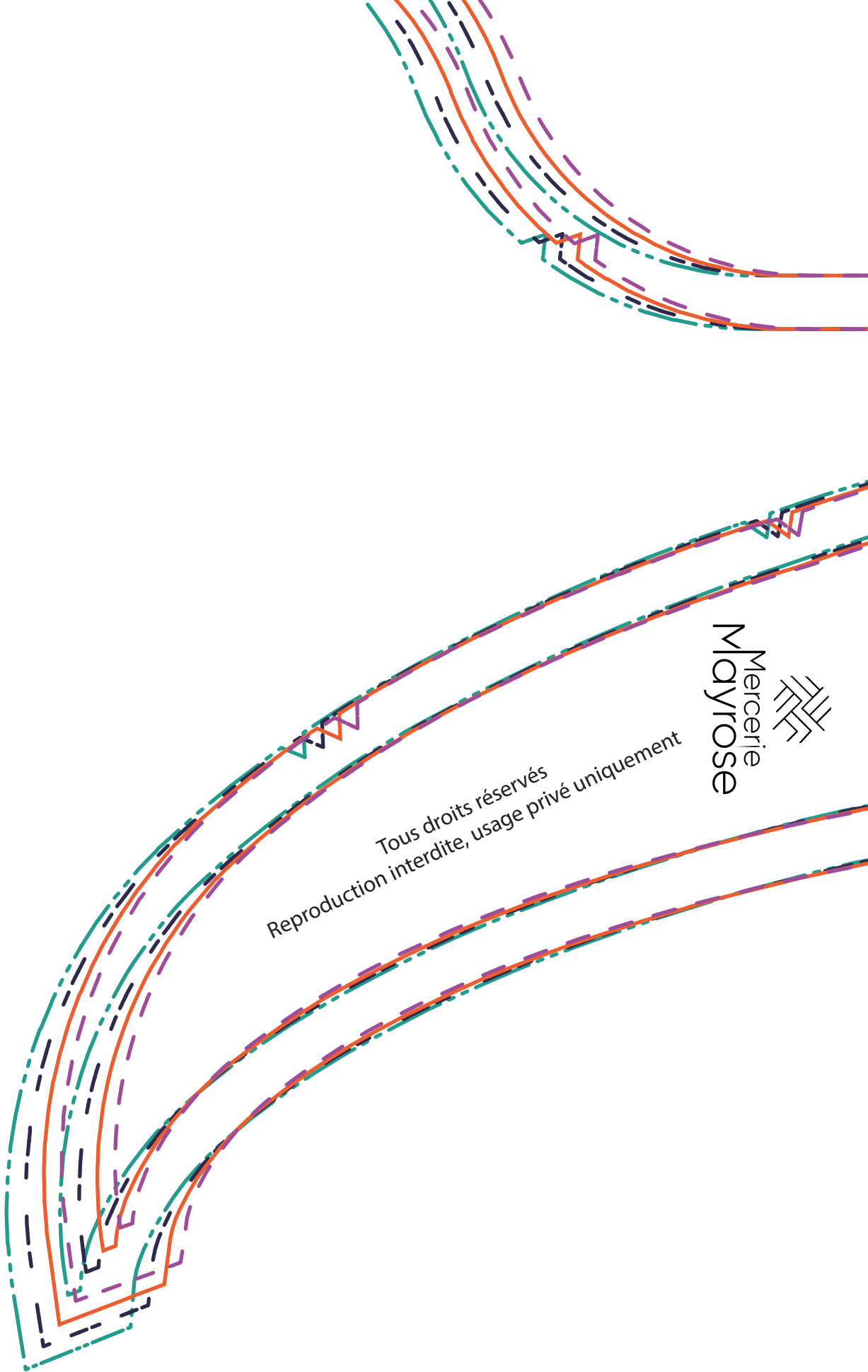

Tous droits réservés
Reproduction interdite, usage privé uniquement

Mercerie
Mayrose

Droit fil →

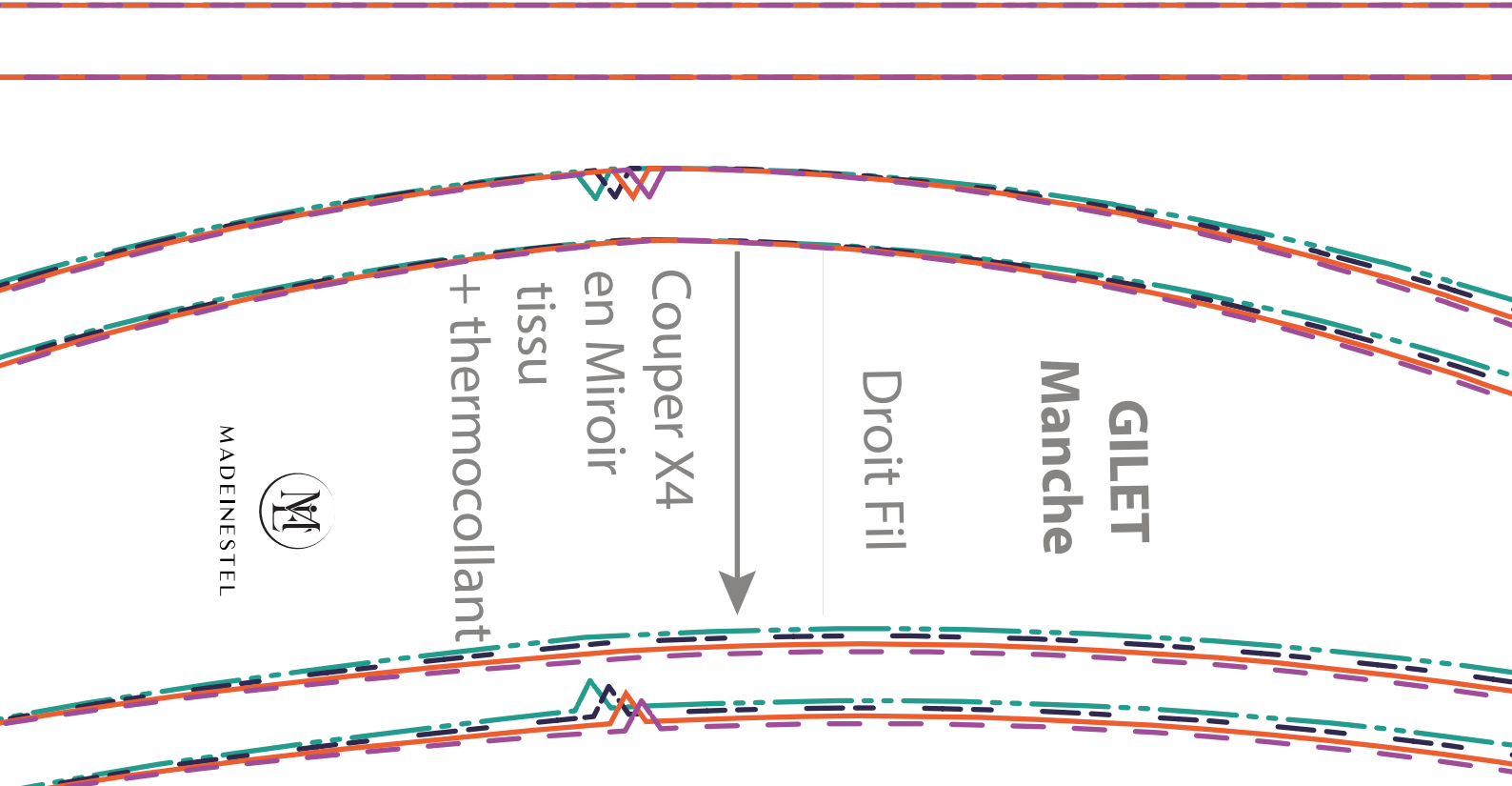

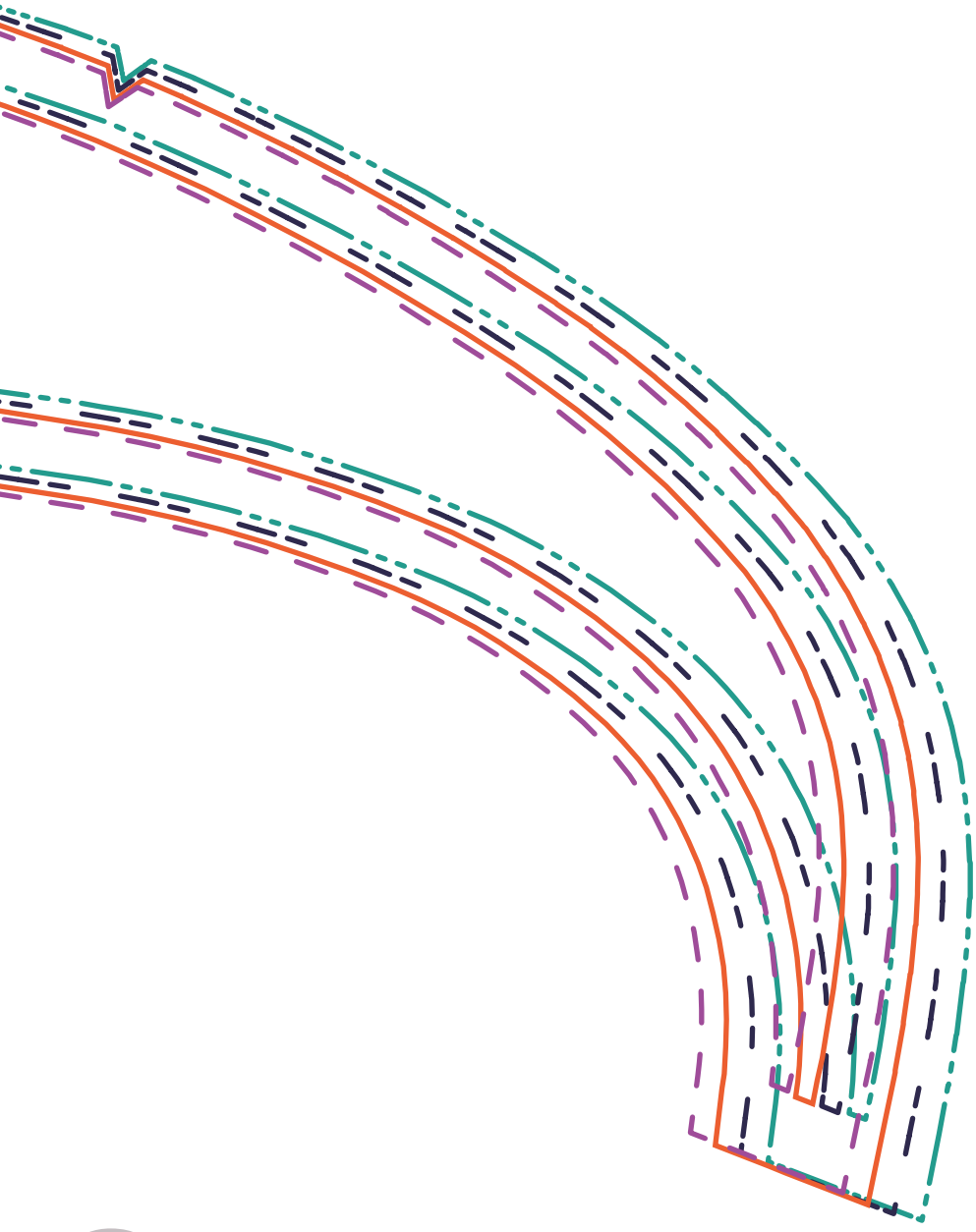
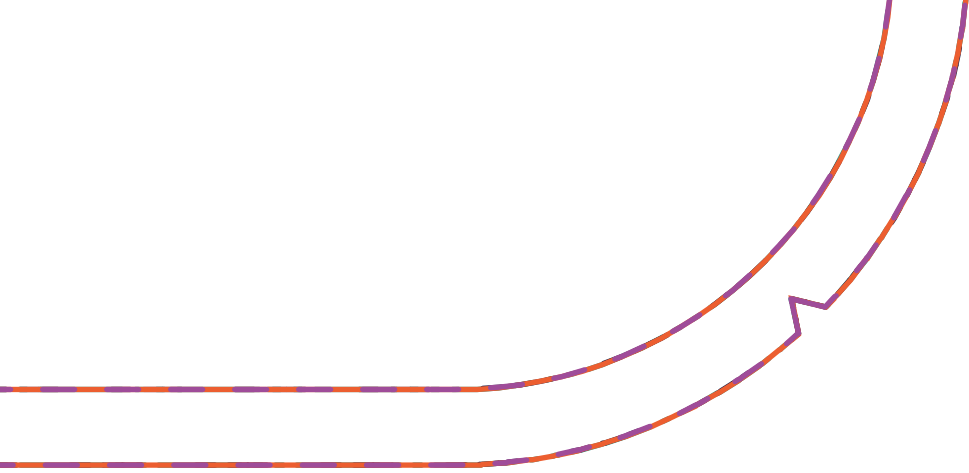

C3



MADEINESTEL



Mercerie
Mayrose

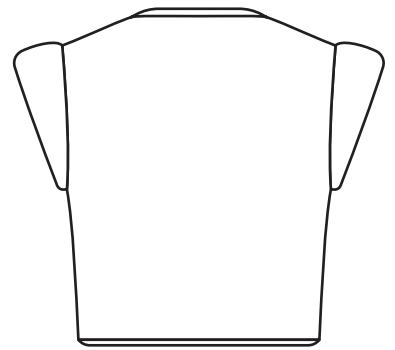
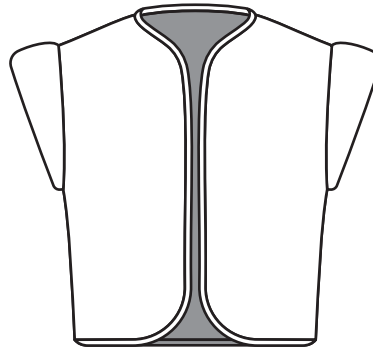
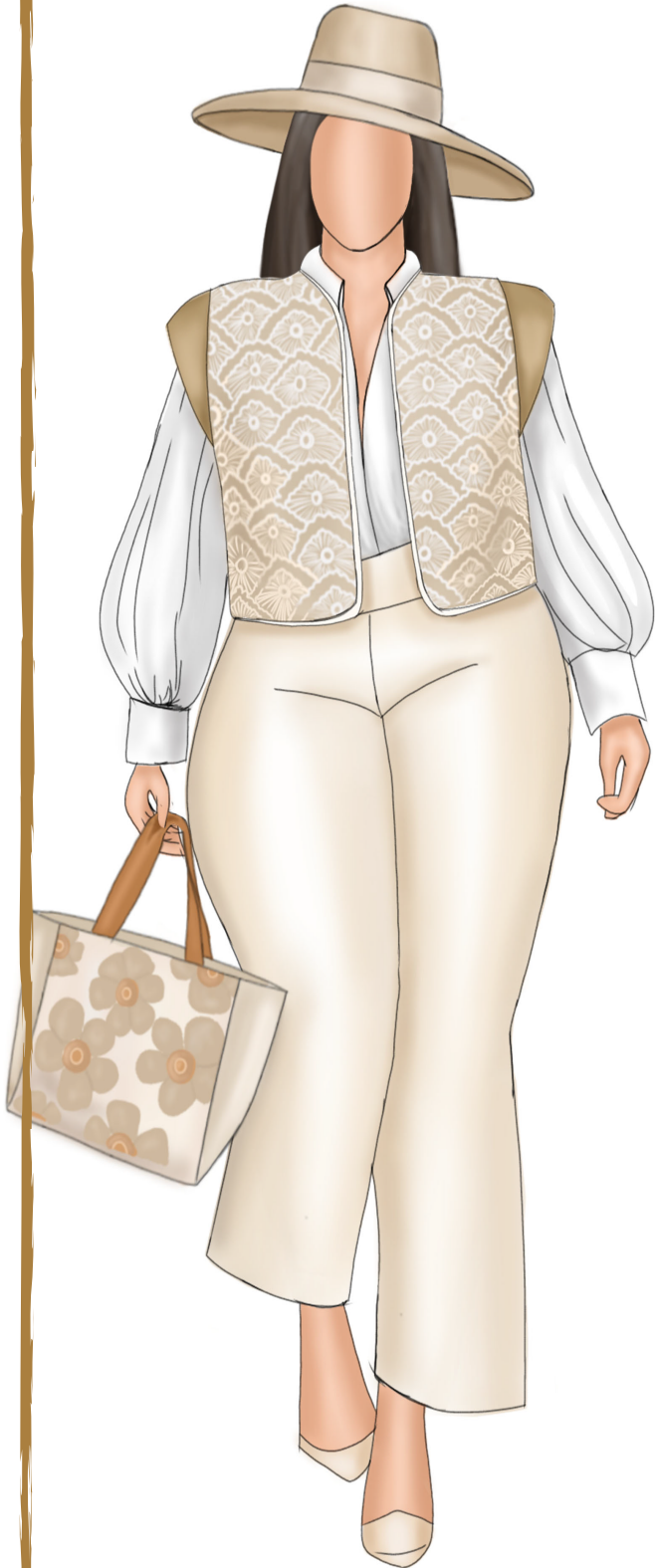

Gilet Rivoli

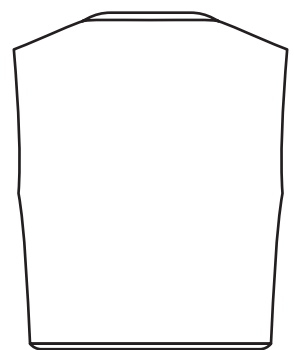
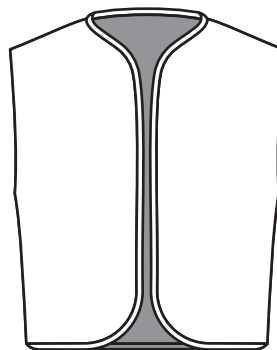

Gilet Rivoli

Tes inspirations ...

Formes: gilet structuré avec mancherons, sans mancherons

Matières: Matelassé, jacquard, natté, jersey matelé, lainage, tweed

Association: bi-matières, texturé/lisse, transparence (dentelle), ajouré

Couleurs: Monochrome, motifs, Tie and dye, patchwork ...

Tissu

Matière:

Composition:

Laize:

Grammage:

Doublure

Matière:

Composition:

Laize:

Grammage:

Biais

Marges de couture

Le premier trait correspond à la ligne «sans marge de couture».

Le second trait correspond à la ligne «marges de couture comprises de 1cm»

NIVEAU DEBUTANT

On choisit sa taille ?

Pour ce gilet, les mesures à prendre en considérations sont surtout le tour de poitrine et le tour de taille.

Taille	46	48	50	52
Tour de poitrine en cm	107	111	115	120
Tour de taille en cm	87	92	96	101
Tour de hanche en cm	115	118	122	126

Tour de poitrine

Tour de taille

Tour de hanche



Matériel

Métrage gilet

Fournitures	46-52
Tissu Corps et mancherons (laize 140 cm)	100 cm
Tissu Corps sans mancherons (laize 140 cm)	60 cm
Doublure (laize 140 cm)	100 cm
Biais	420 cm

Placement des pièces du patron sur tes tissus (laize 140cm)

Tissu Principal
plié en 2

Doublure
plié en 2

Scanner le QRCode avec ton appareil
photo de ton téléphone portable

Fournitures chez
la Mercerie Mayrose

Montage du gilet en
photos

Pas à pas vidéo

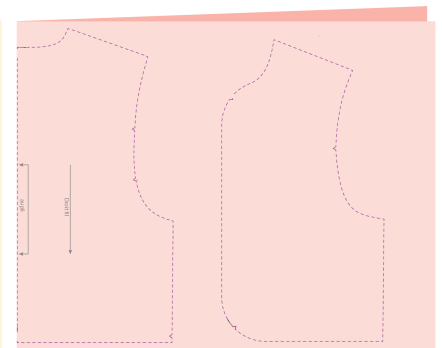
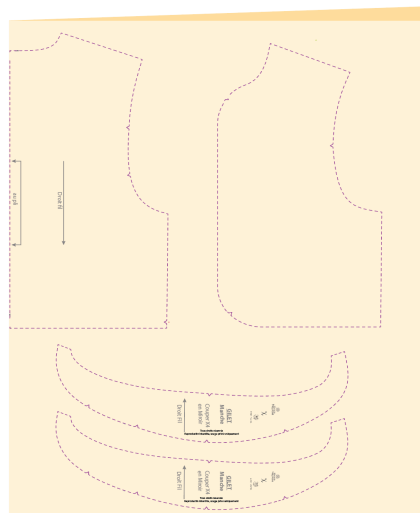



MADEINESTEL



Mercerje
Mayrose

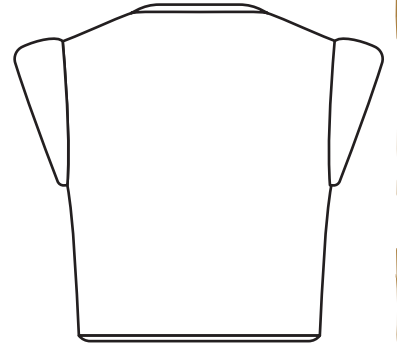
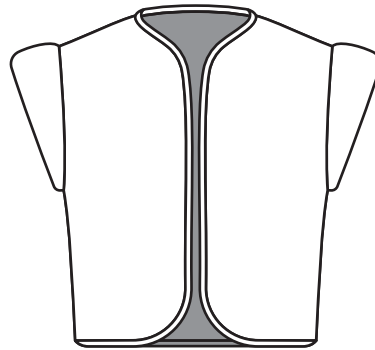

Gilet Rivoli

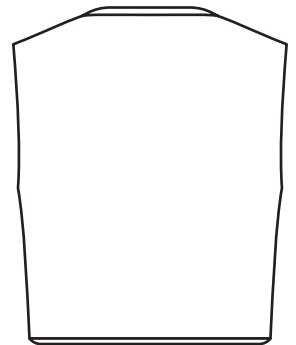
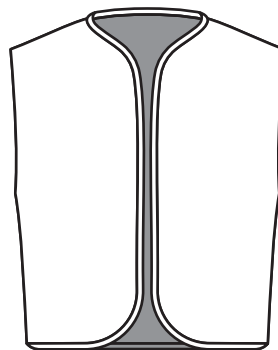

Tous droits réservés
Reproduction interdite, usage privé uniquement



MADEINESTEL



Mercerie
Mayrose

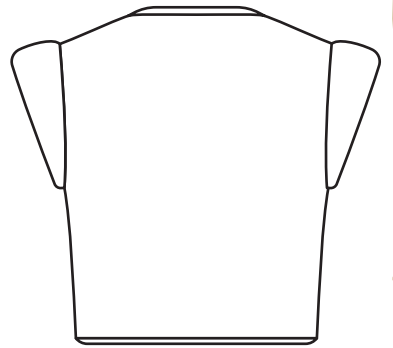
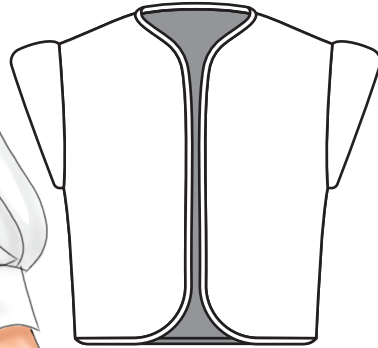

Gilet Rivoli

